



AUTOMASTER

THE AUTO EQUIPMENT SPECIALISTS

Automaster AM-6246R

4500kg 2 Post Clear Floor Hoist



3 YEARS
Warranty



Automaster AM-6246R

4500kg 2 Post Clear Floor Hoist



OUR VICE-GRIP GUARANTEE

If you're not happy, we replace or refund in full.



Available in Dark Blue (5002) or Dark Grey (7016) Colours

SPECIFICATIONS

Capacity	4500KG
Max height	1794-1954mm
Min Height	85mm
Lifting Time (approx)	1PH 52 Sec 3PH 40 Sec
Weight	730kg
Power supply	230V 1PH or 380V 3Ph
Total height	Std 3862 / 3762 High 4162 / 4062
Warranty	3 years

FEATURES

- Only 100mm concrete thickness required (minimum)
- "Double S" single piece construction column design provides channel for the bearings to travel that maximizes the strength of the column
- Can be installed in narrow or wide, high or low configurations
- Full stroke high pressure cylinder in each column minimizes the number of moving parts to maintain and repair
- Remote control for up and lock
- Ultra low lift pads at just 85mm (on perfect floor)
- 3 stage front 2 stage rear arms.
- Suitable to lift large & small cars, vans, 4x4 & utes etc..
- Tool Trays attached to each arm
- Roof protection safety shut down bar across top of hoist
- Top quality motor & pump unit
- Rubber door protection pads on each column
- Low service costs
- High out of the way motor position
- Single control lever to unlock and lower the lift
- Free 80mm long 4 x 4 adapters.
- Optional high version 4162mm
- European CE Safety Certified
- Full 3 year warranty

24V controls

Our lifts are fitted with a low voltage control system as required



C.E. approved locks



Our automatic arm locks are fully approved, tested and safe. Automatically disengage when the lift is lowered

80mm lift pad extensions + holder included



Automaster AM-6246R

4500kg 2 Post Clear Floor Hoist



OUR VICE-GRIP GUARANTEE

If you're not happy, we replace or refund in full.



ASYMMETRIC LIFT

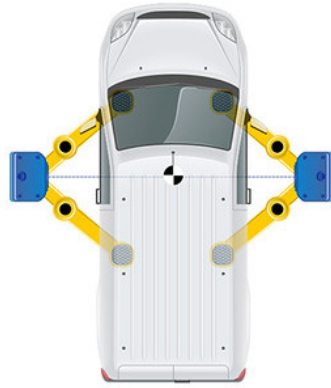

SYMMETRIC LIFT

The Automaster AM-6246R can be installed in **asymmetrical** or **symmetrical** configuration.

Asymmetrical design where the columns are rotated 30° to place the approximate center of gravity of the vehicle in line with the optimum load capability of the column, reducing unnecessary wear and tear on the column, carriage, and bearings. The vehicle sits back further on the lift & since most vehicles are front heavy, only about a third of the vehicle sits to the front while two-thirds hang behind on an asymmetric lift. This makes it easy to open the doors and access the interior of a vehicle.

Symmetrical design with the columns set straight across from each other. The more traditional option, and it's best for shops that work on a variety of vehicles

The most significant benefit of symmetric lifts is that they offer a much larger drive-through area.

Super symmetrical 3 stage front arms allow loading of vehicles asymmetrically or symmetrically when posts are install in the symmetrical position.

SYMMETRICAL

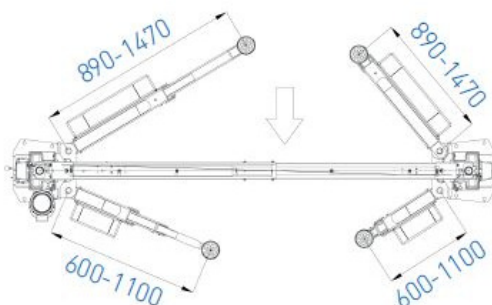
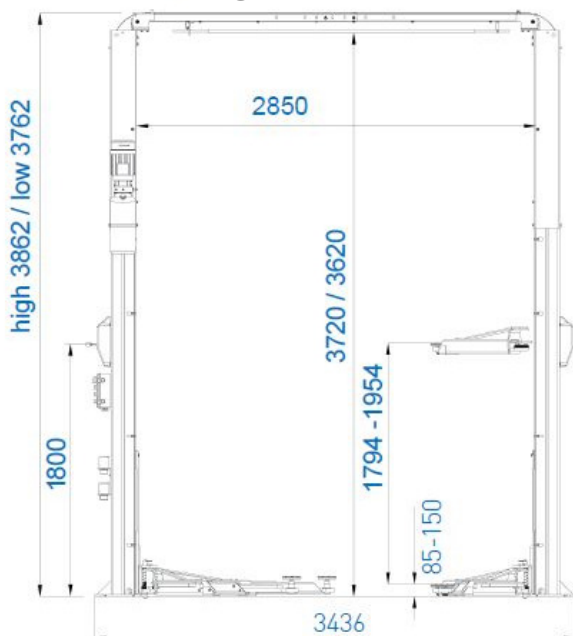

ASYMMETRICAL

